



Ring Plate Series



The Ring Plate Axial Fans are suitable for wall or ceiling mounting and feature a high quality galvanised steel casing and impeller. Their robust construction makes them suitable for a broad range of commercial and industrial applications.

Features

- Powerful air flow and pressure performance
- High quality “Continuous Run” motor
- Can be connected to ducting
- Impeller and fan rings made from durable galvanised steel
- Speed-controllable
- Motor protection IP44
- Auto-reset thermal cutout protection fitted
- Bearings – sealed-for-life, ball
- 220-240V, Single-phase, 50Hz
- Certificate of Approval number: Q98059

Dimensions

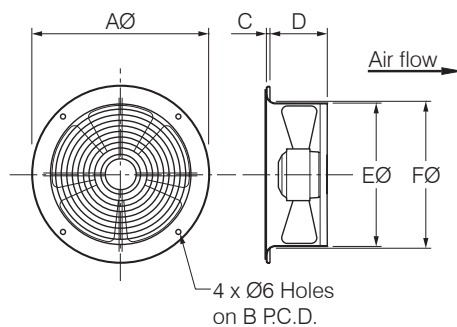

| Model No. RP.. | Duct Size | AØ | B | C | D | EØ | FØ |
|----------------|-----------|-----|-----|---|-----|-----|-----|
| 202/204 | 200 | 280 | 250 | 5 | 95 | 208 | 215 |
| 252/254 | 250 | 320 | 295 | 7 | 103 | 259 | 266 |
| 302/304/306 | 300 | 395 | 375 | 7 | 113 | 310 | 318 |
| 354/356 | 350 | 460 | 422 | 7 | 123 | 360 | 375 |

All dimensions in mm

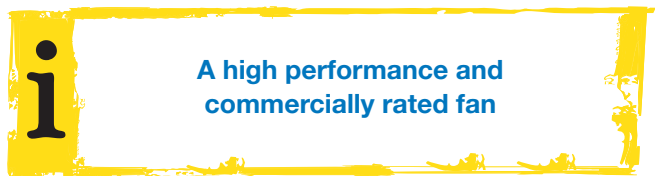

Accessories

- Run-on Timers & Speed Controllers (pages A-38 to A39)
- Flexible Duct - Fire Rated AS/NZS 4254 (page A-40)
- Wall Tubes (page A-47)
- External Grilles (page A-44)

For performance curves and technical data refer to the Fans by Fantech catalogue or visit www.fantech.com.au